

Flow measurement solutions for water and wastewater

ULTRA MAG[®]



With

UltraLiner
TECHNOLOGY

ULTRA MAG

McCrometer has over 45 years of flow measurement experience in municipal, industrial, and agricultural markets. Since its inception, the company has built a reputation for exceptional product quality, timely delivery, and excellent value for the customer. McCrometer is committed

to maintaining these high standards by listening to the needs of its customers, and developing “real world” solutions. Whether you need to measure sludge, slurry, dirty or clean water, we will work with you to deliver the right product at the right price. Contact your McCrometer representative today for a free flow evaluation.



*Your flow
measurement
specialists*

ULTRA MAG®

Designed for water and wastewater applications

The Ultra Mag® from McCrometer is an advanced electromagnetic flowmeter designed specifically to meet the needs of the water and wastewater industry. With innovative features, such as the UltraLiner™ fusion-bonded epoxy liner and a state-of-the-art microprocessor-based signal converter, it delivers exceptional accuracy of $\pm 0.5\%$, reliability and durability, even in harsh environments. It also offers a wide rangeability, accurately measuring flows as low as 0.2 FPS.

Performance advantages

The key to the Ultra Mag's high performance lies in several unique features. The first is the use of advanced UltraLiner technology. This NSF-approved epoxy liner gives the flowmeter outstanding electrical insulating properties while providing superior abrasion and corrosion resistance, and enhanced durability, with no liner delamination or separation. The highest possible accuracy is further guaranteed by the Ultra Mag's microprocessor-based signal converter, which uses advanced electronic components to produce a very high signal to noise ratio. The meter's flanged end tube design permits use in a wide range of municipal applications including use in water, wastewater, slurries, and sludge.



typical applications

potable water
wastewater management
water well production
rate-of-flow controller
pump stations
truck loading and unloading
raw water transmission lines
wastewater effluent

UltraLiner
TECHNOLOGY

How does the unique UltraLiner technology give you the most accurate, reliable and durable electromagnetic flowmeter on the market?
Get the answers at
www.ultraliner.org

How the Ultra Mag operates

The Ultra Mag is a non-invasive flow measurement device.

It uses two compact, high density magnetic coils to generate an electromagnetic field inside the pipe section.

As conductive liquid flows through the pipe, a voltage is created, which is measured by electrodes inserted through the flowmeter lining into the flow.

The voltage is converted to a flow rate reading by the Ultra Mag's signal converter and shown on the digital display.

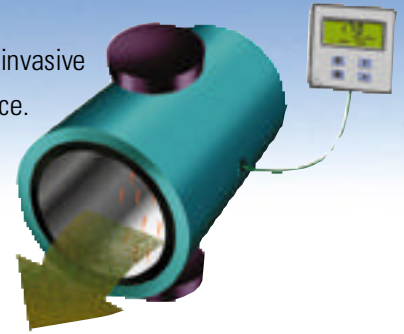

Why magmeters are the best choice

Magmeters provide worry-free flow measurement in situations where reliability and low maintenance are critical. Unlike mechanical flowmeters, they have no moving parts to maintain and cannot clog, making them ideal for hard-to-reach locations. The lack of moving parts also ensures minimal headloss. Electromagnetic measurement is very versatile, giving magmeters a wide rangeability of 245:1 and allowing for bi-directional flow readings. And, because the voltage generated is related only to the speed of the fluid, measurement is unaffected by changes in fluid density and viscosity, making a very stable and reliable flowmeter.



Microprocessor-based signal converter

Pulsed DC magnetic field excitation provides the highest accuracy, absolute zero stability and saves considerable energy compared to AC excitation.

Signal to noise ratio is a term used to describe the relationship between actual flow signal and process noise. A high ratio will produce a strong flow signal and less noise. Combining two or more phase liquids, suspended solids and rapid changes in fluid conductivity can all create process noise. The Ultra Mag® is designed to have a very high signal to noise ratio.

Selectable coil excitation frequencies are required to maximize the induced voltage registered by the signal converter on different sizes of flow meters. The opposition offered by the conductive liquid in passing the induced current is known as resistance. The conductive liquid and bore or distance between the sensing electrodes determines how much resistance will be applied. Small-bore meters apply little resistance where larger meters apply significantly more. The required oscillation frequency is established at the factory's flow calibration laboratory based on optimum performance levels for each meter.

Magnetizing current provided to the magnetic coils is 1 amp peak to peak.

Signal converter programming is user defined and password protected. It is performed via the keypad or through the RS-232 communication port. All data is stored in a non-volatile memory with a 10-year retention.

Output interface comes standard with the signal converter. Included are a single 4 – 20 mA DC output, two programmable pulse outputs and two control alarm outputs. HART® Communication and independent, bi-directional, 4 – 20 mA DC outputs are optional.

Automatic self-check feature continuously monitors the flowmeter and offers failure diagnostics on screen.

Bi-direction flow measurement is inherent to the design of a mag meter. Local flow rate indication and 3 separate totalizers (forward, reverse, and net total) come standard with every unit.



Ultra Mag uses state-of-the-art electronic components for accuracy and reliability



Provides protection and electrical insulation

UltraLiner™ is the latest technology in the development of liners for electromagnetic meters. This unique process creates a fusion bonded epoxy liner applied via the fluidized bed method. The result is a highly protective coating with non-conductive properties. The UltraLiner provides superior electrical insulation as well as excellent protection against corrosion and abrasion.

Added advantages of UltraLiner™

- Non-conductive to eliminate stray currents
- A liner that also acts as an electric insulator
- Greater abrasion resistance than hard rubber coatings
- Excellent protection against abrasion, corrosion and wear
- Will not collapse or delaminate when used on suction lines like Teflon liners can



Installation

These are the various installation configurations for the Ultra Mag. In all cases, the sensor must be completely filled with liquid to ensure an accurate measurement.

For information specific to your application, contact your nearest McCrometer representative.

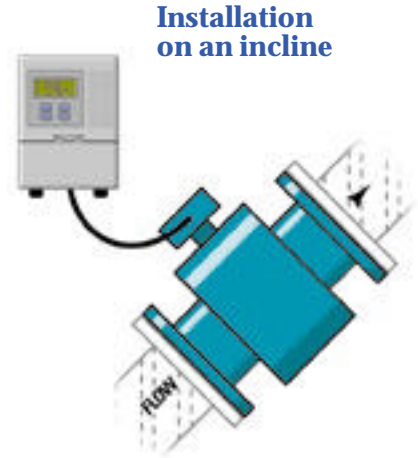
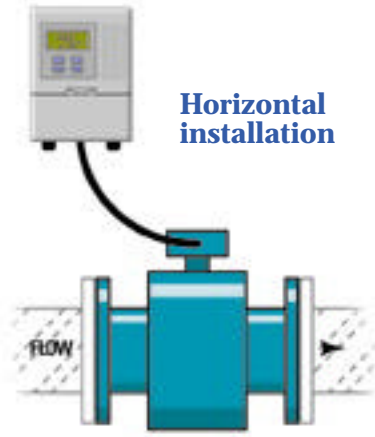

Vertical installation

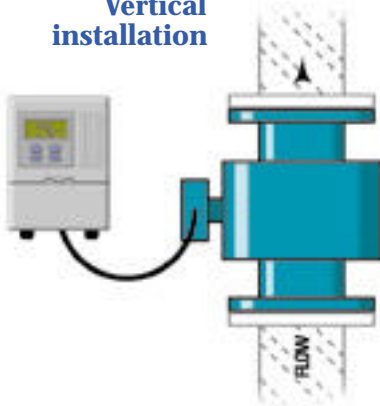

Trap to ensure a full pipe

To ensure accuracy, the sensor must always be completely filled with liquid

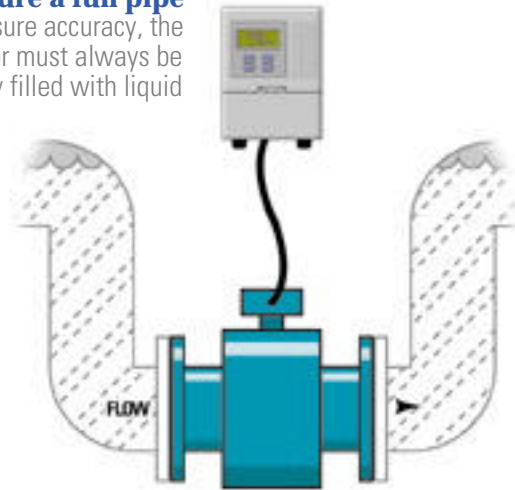

For illustration purpose only

Refer to Recommended mating conditions for upstream and downstream requirements

Standard keypad display

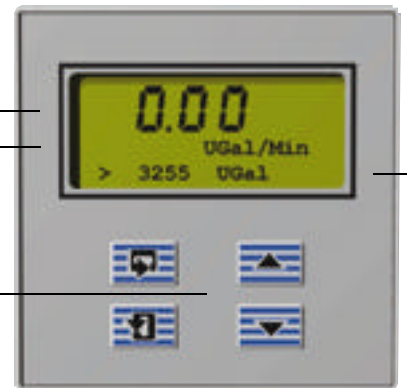

Flow rate
Alarm/flow rate units

Membrane keys
for access adjustments to all parameters, totalizer reset (bottom right), and to scroll through all data (bottom left).

- Data**
- Forward flow total
 - Reverse flow total
 - Net flow total
 - Alarms
 - Flow velocity in m/s or ft/s
 - Flow rate % of range



Specifications

Configuration

Signal converter is mounted remotely from sensor on all sizes.

Separation

REMOTE SIGNAL CONVERTER

The maximum cable length is the lower of 300 feet or 15 x the conductivity ($\mu\text{S}/\text{cm}$).

Accuracy

UNDER REFERENCE CONDITIONS

Display, serial comms, frequency output

$\pm 0.2\%$ of reading or ± 0.003 ft/sec (0.001 m/s), whichever is greater, up to a maximum velocity of >49 ft/sec (15m/s).

Analog output

As frequency output plus ± 0.008 mA.

Pressure effects

Less than 0.15% over the operating range of the instrument.

Temperature effects

Transmitter

Display, serial comms, frequency output

$< \pm 0.08\%$ of reading per 10°C

Analog output as frequency plus

$< \pm 0.08\%$ of reading per 10°C

Repeatability & reproducibility

$\pm 0.05\%$ or ± 0.0008 ft/s (± 0.25 mm/s), whichever is greater.

Power supply variation

Negligible effect

Within published specification

Conductivity

Liquids and slurries having a conductivity of not less than $5\mu\text{S}/\text{cm}$ ($5\mu\text{mho}/\text{cm}$).

Mounting

Directly into pipeline at any attitude.

Electrodes should not be on a vertical plane.

Recommended mating pipe conditions

Upstream

5 diameters of straight pipe from the center of the meter to any normal obstruction is sufficient to obtain specified accuracy. Partially opened valves, 90- or 45-degree elbows, and pump discharges located upstream of the installation require 10 diameters. All blending and chemical injection should be done early enough so the flow medium is thoroughly mixed prior to entering the measurement area.

Downstream

2 diameters of straight pipe from the center of the meter.

Power consumption

Less than 20VA

Warm-up time

 1 minute

Calibration

 3-point, 8-point or witnessed

Sensor cable connection

0.5 inch NPT single opening. A single cable is provided for the coil drive and electrode signals.

Sizes

NOMINAL BORE

2 – 48 inch (50 mm – 1200 mm)

Consult factory for other sizes

Metering tube

Configuration methods

All configurations are user defined and password protected. The configuration is stored in non-volatile memory with a 10-year retention.

The converter is fully programmed before shipping. Reprogramming can be easily done on site using the following methods:

Keypad can be used to access and change all menu parameters using four membrane keys and 3-line display.

RS-232 standard 9-pin data connection for local hand-held terminal or computer

(null modem/Lap Link cable required). Software such as ProComm Plus,

Windows, PC Tools, or our communications option is required.

RS-423/RS-422 option for remote serial communication

HART® Communications

Material

Lined stainless steel (304 SST)

Liner

UltraLiner™ NSF approved, fusion-bonded epoxy

Electrodes

Non-removable (316 SST)

Grounding ring

Recommended (316 SST)

Flanged Meters

Sizes 2-inch to 48-inch (50 mm to 1200 mm) with maximum working pressure 150 or 300 psi (300 psi not available larger than 20-inch).

Process Connections

Flanged meter-carbon steel flanges to mate with ANSI flanges

Temperature

Ambient: -10 to $+77^\circ\text{C}$ (14 to 170°F)

Environmental

Protection

Flanged sensors, with remote converter. NEMA 6P/IP68 with potted terminal box and cable.



Signal Converter

Displays

Keypad 3-line, 16-character, backlit display with large ½" numerals for flow rate and two lines for engineering units, totalizers, alarm status, velocity and percent of range.

Internal totalizer

Resettable 9-digit for forward, reverse and net totals. Can be programmed to reset via external input.

Time constant

Fully programmable from 2 to greater than 120 seconds.

Test mode and output circuit loop verification

After converter has been programmed, operation of the test mode will drive outputs to programmed value to provide total system test.

Power supply

Universal switch mode.

AC 85 to 265V 45 to 400 Hz at 20VA maximum **or**

DC 11 to 40V at 20VA maximum

High input impedance

10¹⁵ OHM performance allows non-conductive coatings on the electrodes to be ignored. Eliminates the need for removable electrodes or electrode cleaners.

Outputs

Standard

- 1. Analog** Fully programmable for zero, full scale, up to 21mA and flow direction. Fully isolated. Output capability 16 (800 ohm, 4 – 20mA). Secondary range enabled by external input or programmed alarm condition as a percent of full scale.
- 2. Pulse/frequency** One frequency/pulse output for forward and one for reverse flow. Forward and reverse flows 0 to 800 Hz square wave or fixed pulse width up to 2.5 sec. Fully programmable for pulse rate, pulse factor, low flow cutoff, pulse width, etc. Minimum frequency/resolution <0.1 pulse/day. Frequency limit settable 1Hz – 800 Hz in 1Hz steps. Isolated protected transistor switch capable of sinking <250mA. Voltage <35V.
- 3. Dual alarms** 2 separate outputs. Isolated protected transistor switch capable of sinking <250mA. Voltage <35V. **NOTE:** Not isolated from frequency output. Fully programmable for high/low rates, percentage of range, empty-pipe zero, fault conditions, forward/reverse polarity (Normally open/close), analog over-range, pulse over-range, pulse cutoff, etc.
- 4. RS-232C** 9-pin data connector for local hand-held configurator or any computer with serial communications.

Optional

- 1. Dual analog** Additional analog outputs for re-ranging (provides two separate inputs to a recorder/controller). Only one output is active at a time. Nonactive output is 4mA.
- 2. Serial communication RS-423/RS-422** Compatible data link (via terminal block).
- 3. HART® Communications**

Input

An external input such as contact closure, open collector voltage, or logic signal can be used to:

1. reset totalizer
2. change range (span)
3. hold the output constant
4. drive the output to zero
i.e., empty pipe or partial filled pipe conditions.

Note: Not isolated from pulse and alarm outputs.

Isolation

Galvanic separation to 50V DC between analog, pulse/alarm, and earth/ground.

Temperature

Operating -10 to +77°C (14 to 170°F)

Storage -15 to +77°C (5 to 170°F)

Enclosure

Case is NEMA 4X/IP65 rated with separate termination and electronic compartments. It is constructed of glass filled polypropylene, and has a polycarbonate window.

Electrical connections 0.5 inch NPT with gasket seal.

Approvals CSA, General Purpose.

Meets

Electrical safety BS4743 Class 1. (IEC 348).

Vibration specification BS2011: Part 2.1 Fc: 1983.

EMC Specification

1. Conforms to BS6667 Part 3 *Radiated susceptibility to 10V/m*
2. Conforms to BS6527 *Terminal voltage and radiated emissions*
3. Conforms to BS800 *Interference Power*

HART® Communication

The Ultra Mag converter HART option allows communications via the HART field communications protocol using a communications device connected to points located anywhere in the 4 – 20mA current output circuit wiring. Ultra Mag also supports a multi-drop system and permits up to fifteen Ultra Mag converters on a single pair of wires without losing the 4 – 20mA signals on the individual meter. The unit can be configured with universal HART Communications such as the Rosemount 275 or 268 (version 6 or higher). HART burst mode is also supported, enabling regular transmission of selected data.

Self-diagnostic

Signal converter confirms correct operation of hardware with fault diagnosis, e.g. coil drive problems.

Empty pipe detection

Programmable for conductivity trip point. Liquid level sensing results in drive to zero (i.e., empty pipe zero when electrodes are uncovered). For Process Mode only. Also can drive output to zero via external input in process or slurry mode.

Interchangeability

Signal converters are fully interchangeable with all sizes of Ultra Mag sensors and can be configured on-site. System specification not affected by converter change.

Test equipment

Flow signal simulators for testing and checking the electronic calibration of the Ultra Mag converter are available.

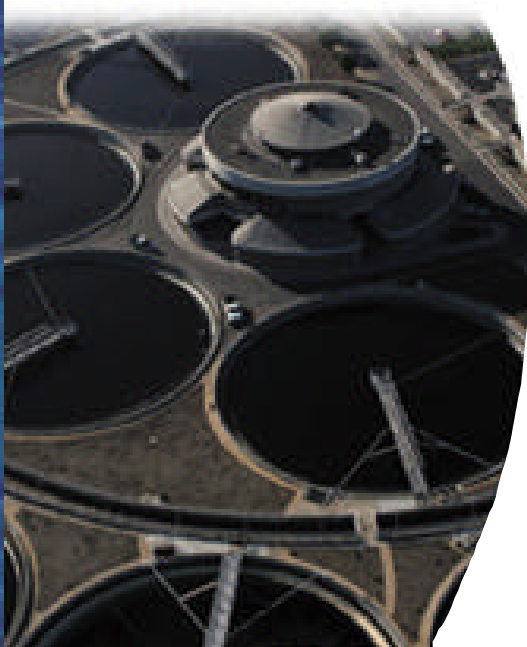

- Accuracy of $\pm .5\%$ of actual flow
- Velocity range of .2 to 49 FPS
- Pressure rating of up to 300 PSI
- Operating temperature up to 170° F
- Electrodes are Type 316 stainless steel
- Bullet-shaped, self-cleaning electrodes
- Factory pre-programmed
- Microprocessor-based signal converter
- NIST traceable wet flow calibrated
- Bi-directional scaled pulse
- NSF approved fusion bonded liner
- CSA approved
- Resettable totalizer
- Protected from configuration parameters lockout
- Forward and reverse flow indication and totalization
- Self-diagnostic test mode
- Two programmable alarm outputs
- Backlit digital readout
- Rate of flow and total volume displayed continuously

Optional Equipment

HART® Protocol compatibility

Separate 4 – 20 mA output for reverse flow

Submersible and buriable flow sensors (NEMA 6)

316 SS grounding rings

Complete line of instrumentation

ULTRA MAG®

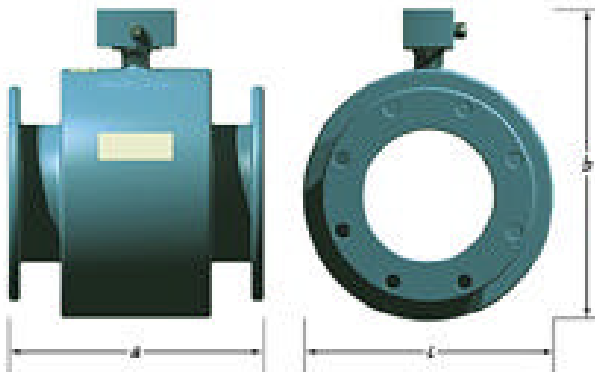

nominal size INCHES	DIMENSIONS + INCHES			approx. weight POUNDS*	FLOWRATES + G.P.M.	
	a	b	c		min at rated accuracy	max at rated accuracy
2	11.0	11.3	7.9	55	2	479
3	13.4	12.8	9.4	70	5	1,079
4	13.4	13.8	10.4	80	8	1,919
6	14.6	15.9	12.5	150	19	4,318
8	16.1	19.2	15.7	230	33	7,676
10	18.5	21.3	17.8	264	52	11,995
12	19.7	22.8	19.4	328	74	17,273
14	21.7	24.1	20.3	442	90	23,510
16	23.6	26.1	21.1	458	118	30,707
18	23.6	27.9	21.1	550	150	38,864
20	25.6	30.1	24.8	661	185	47,980
24	30.7	34.3	29.6	815	268	69,092
30	35.8	40.8	35.9	1,330	420	107,956
36	46.1	48.0	42.7	1,450	609	155,457
42	46.1	54.0	47.3	1,600	834	211,594
48	47.2	61.2	55.6	2,240	1,094	276,368

*with 150 PSIFlanges

3255 West Stetson Avenue, Hemet, California 92545-7799, USA

PHONE 909.652.6811 FAX 909.652.3078

EMAIL info@mccrometer.com

WEB www.mccrometer.com

