

Series C/CT/CN/CB

Series C Filter Chambers

Flows to 10,800 gph

*Removes Solid Dirt Particles
Quick Change Cartridge
Choice of Construction Materials
Can Use Filter Cartridges, Submicronic
Pleated Cartridges or Filter Sleeves*

Series CT Carbon Treatment Chambers

Flows to 3780 gph

*Removes Organic Contaminants &
Solid Dirt Particles
Easy Conversion to Filter Chamber
Choice of Disposable Carbon Cartridge or
Bagged Granular Carbon
Recommended For Purification Filtration of:
Bright Plating Baths Acid or Alkaline Solutions
Precious Metal Baths Other High Purity Solutions*

Series CN In-Tank Filter Chambers

Flows to 2160 gph

*Complete In-Tank Filtration
Removes Solid Dirt Particles
Quick Change Cartridge
Rugged CPVC Material of Construction
including Mounting Bracket*

Series CB Filter Bag Chambers

Flows to 4800 gph

*Corrosion Resistant CPVC Construction
Filtration Down to 1 Micron
Simple Filter Bag Replacement
High Volume Surface Filtration
Lower Initial Cost & Reusable Filter Media
Economical Solution to a Variety of Corrosive
Filtration Requirements*

Penguin offers a wide range of chambers in CPVC, polypropylene and PVDF. Construction contains no fragile lucite or glass. There is no metal to liquid contact, no springs to lose or break, and no crushed tubes. Penguin CPVC and polypropylene chambers are recommended for most acid and alkaline solutions. PVDF chambers are recommended for high temperature acids and alkalis, HF, and electroless nickel. All Penguin chambers can be mounted on a common polypropylene base and manifolded together for greater capacities or space saving requirements. For portability, casters can be added as an option.

Penguin filter chambers are available in single tube, three



Penguin Chambers

Features:

- Leakproof
- Corrosion Resistant
- Unique Penguin Design -
No Liquid Bypass
No External Frame Rods

Model 12C-36A

tube, five tube, and twelve tube vessels. Each filter chamber is equipped with an initial Penguin 15 micron filter cartridge or set of filter cartridges. Because of the unique Penguin design, these cartridges ensure maximum particle retention and no liquid bypass. Our series CB chambers include a 5 micron filter bag. Our style 6C/6CT, 8C/8CT, and 12C/12CT chambers come equipped with a Penguin pressure gauge/guard assembly and air bleed valve. As an option, this gauge and guard assembly can also be placed on the inlet or discharge line of our style 3C/3CT or 4C/4CT chambers.

Series C/CT/CN/CB

Series C

Filter Cartridge Chambers

Style 3C

The most economical of filter chambers, this single cartridge unit will accommodate 6", 10", 20", or 30" length cartridges. The 10" cartridges may not be stacked inside a 20" or 30" chamber because there is no center rod. Because of the unique cartridge compressor design, this chamber can accept a cartridge length variance of 1/4" without any liquid by-pass. The special top knife edge moves up and down with the filter cartridge length. There are no longer any center rods protruding through the chamber top to break or stretch, and the top is now threaded onto the shell via an acme thread configuration. The inlet and outlet ports have been increased from 1/2" MPT to 3/4" FPT connections as well as the chamber diameter, to increase the filtration flow rate and to eliminate the possibility of broken MPT inlet/outlet connections. A base is included for surface mounting. Our series CN includes a B-mount bracket for mounting the chamber on a tank lip without a base for minimal space requirements. This chamber can accept double open end, single open end with internal #020 o-ring, or double open end with internal #120 o-ring each end.



Model 3C-1A



Model 3C-1B



Model 3C-1C

Style 4C

This heavy-duty single cartridge chamber will accommodate 10", 20", or 30" length filter cartridges. Because of the internal rod design, this chamber can accept various filter cartridge lengths $\pm 1/4$ " without liquid bypass. The 4C chamber can accommodate non-standard cartridge lengths with more than the 1/4" length from standard by adjustment of the internal rod length. Consult the factory for details. The special head is threaded onto the shell via a Dardelet, self-locking thread configuration. The 1" FPT inlet/outlet connections and 4" chamber diameter allow for increased filtration flow rates, especially for larger O.D. sub-micronic cartridges (2.50"-2.90" O.D.), while also eliminating the possibility of broken MPT connections.



Model 4C-1A



Model 4C-1B



Model 4C-1C

Style 6C/8C/12C

These three filter chambers incorporate heavy reinforced ribbing within the molded parts. The double labyrinth o-ring sealing and the long-sleeved flanges, top and bottom, allow these chambers to operate at higher pressures and/or temperatures while also eliminating the use of external frame rods. The simplicity in design and accessibility allows one to completely disassemble and reassemble these chambers in order to replace any broken or damaged part. These chambers can also be converted in the field to a carbon treatment unit or to accept single open end, double #222 o-ring seal sub-micronic cartridges with only a small modification. This simple conversion process eliminates the expense of purchasing a completely new chamber.



Model 6C-6A



Model 8C-15A



Model 12C-48A

Penguin Chambers

Series C/CT/CN/CB

Series CN

In-Tank Filter Chambers

Penguin in-tank filter chambers allow for depth filtration completely limited to inside the tank. Thus, there is no possibility of solution loss. These filter chambers are completely constructed of CPVC, including the rugged mounting bracket. Five sizes include single cartridge and three cartridge vessels in 10", 20", and 30" cartridge lengths. These chambers incorporate all the unique construction advantages of our style 3C and 6C chambers. The cartridge compressor design in the style 3C chambers and the double labyrinth o-ring sealing, along with the long-sleeved flanges on the top of style 6C, are also incorporated into our series CN chambers.

Series CT

Carbon Treatment Chambers

Penguin carbon treatment chambers are available with carbon cartridges or bagged granular carbon. Each carbon cartridge chamber comes equipped with a Penguin series PC disposable carbon cartridge containing pure, low sulfur, activated carbon granules. All carbon cartridges can be replaced with filter cartridges if straight filtration is required. Carbon bag chambers contain a reusable polypropylene mesh bag to be filled with Penguin style GC sulfur-free, activated granular carbon. Depending upon the style selected, the chamber holds from 5 to 100 pounds of carbon. When the carbon becomes exhausted, only the granular carbon, and not the bag, needs to be replaced. Penguin granular carbon quickly reaches its saturation point in absorbing minimal amounts of brighteners, yet continues to have excellent absorption for organic impurities. Following organic decontamination, the solution is automatically depth filtered through a 3 micron filter surrounding the core of the carbon cartridge or set of 3 micron filter cartridges attached to the carbon bag chamber head. This traps all foreign particles and solids. Carbon bag chambers can easily be converted to straight filtration if required. All carbon bag chambers come equipped with a flow plate, polypropylene mesh carbon bag, short and long filter cartridge rods, and an initial set of 3 micron filter cartridges used during carbon treatment.

Style 3CT/4CT

For smaller tanks when a single carbon cartridge is adequate, these heavy duty carbon treatment chambers will accommodate a 10", 20", or 30" carbon cartridge. These chambers incorporate the same unique engineering designs as the Penguin style 3C/4C chambers. If straight filtration is required, a filter cartridge can replace the carbon cartridge.

Style 6CT/8CT/12CT

Incorporating all the features of the 6C/8C/12C filter chambers, these carbon treatment units contain a reusable polypropylene mesh bag to be filled with Penguin low sulfur granular carbon. These carbon bags can hold up to 100 pounds of carbon. These chambers can also be easily converted into total filtration chambers, with the 6CT, 8CT, and 12CT holding 3, 5, and 12 cartridges, respectively.

Series CB

Filter Bag Chambers

Penguin filter bag chambers are designed for high volume surface filtration. Completely constructed of CPVC, these filter chambers allow for filtration down to 1 micron. Filter bag replacement is easy with the removal of one snap ring. There are four sizes incorporating all of the construction advantages of our style 6C and 8C chambers. The double labyrinth o-ring sealing and the long-sleeved flanges, top and bottom, allow these chambers to operate at higher pressures and/or temperatures while eliminating the use of external frame rods.

Penguin Chambers



Model 3CN-1A

Model 6CN-6A



Model 3CT-1A

Model 4CT-1A



Model 6CT-9A

Model 8CT-15A

Model 12CT-36A



Model 6CB-9A

Model 8CB-15A

Series C

Filter Cartridge Chambers

Series C Specifications

Chamber Style	GPH based on 70° Water * Wound Cartridge	Cartridge No. & Length		
		Wound Cartridge	Pleated Cartridge	
			DOE	SOE
3C-6	0-160	1-6"	1-6"	1-6"
3C-1	150-300	1-10"	1-10"	1-10"
3C-2	300-540	1-20"	1-20"	1-20"
3C-3	450-720	1-30"	1-30"	1-30"
4C-1	150-300	1-10"	1-10"	1-10"
4C-2	300-570	1-20"	1-20"	1-20"
4C-3	450-810	1-30"	1-30"	1-30"
6C-3	450-900	3-10"	3-10"	2-10"
6C-6	900-1620	3-20"	3-20"	2-20"
6C-9	1350-2160	3-30"	3-30"	2-30"
8C-5	750-1500	5-10"	5-10"	4-10"
8C-10	1500-2700	5-20"	5-20"	4-20"
8C-15	2250-3600	5-30"	5-30"	4-30"
8C-20	3000-4800	5-40"	5-40"	4-40"
12C-12	1800-3600	12-10"	12-10"	9-10"
12C-24	3600-5760	12-20"	12-20"	9-20"
12C-36	5400-7560	12-30"	12-30"	9-30"
12C-48	7200-8640	12-40"	12-40"	9-40"

* Higher flows available with pleated cartridges.

Series C Dimensions

Chamber Model	Inlet	Outlet	Dimensions							Shipping Weight
			A	B	C	D	E	F	G	
3C-6	3/4"	3/4"	10 1/2	1	2 5/8	5 1/4	5 1/4	N/A	N/A	3
3C-1			14 1/2							4
3C-2			24 1/2							6
3C-3	34 1/2	8								
4C-1	1"	1"	17 1/8	1 3/8	3 1/2	7	7	N/A	N/A	7
4C-2			27 1/8							10
4C-3			37 1/8							13
6C-3	1"	1"	22	8	5	10	3 3/8	29 3/8	27	27
6C-6			32							36
6C-9			42							45
8C-5	1 1/2"	1 1/2"	23 1/8	8	6	12	N/A	2 3/8	31	33
8C-10			33 1/8							45
8C-15			43 1/8							57
8C-20	53 1/8	69								
12C-12	1 1/2"	1 1/2"	22 3/4	8	16	N/A	2 1/4	30 3/4	70	70
12C-24			32 3/4							90
12C-36			42 3/4							110
12C-48			52 3/4							130

Penguin Chambers

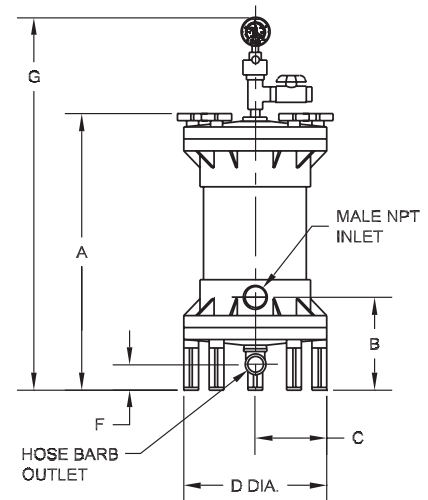
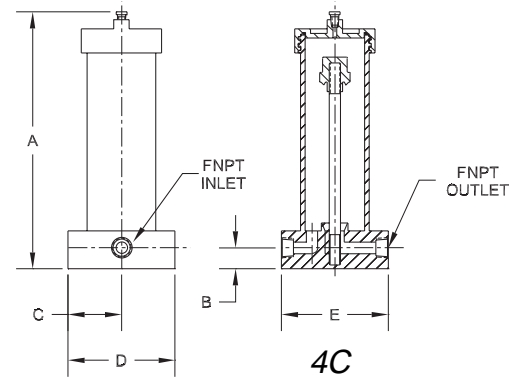
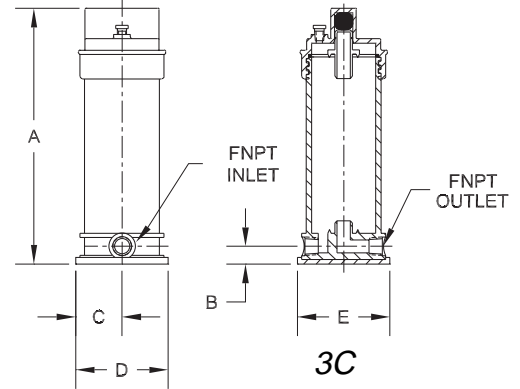

6C/8C/12C

Mounting Dimensions

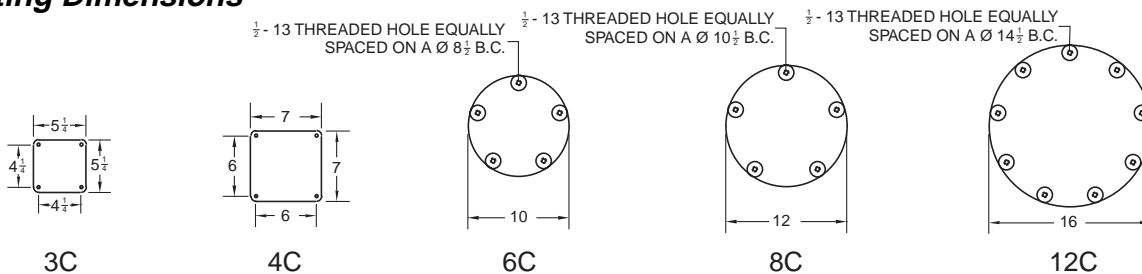

Series CT

Carbon Treatment Chambers

Penguin Chambers

Series CT Specifications

Chamber Style	GPH based on 70° Water	Carbon Cartridge Chamber		Bulk Carbon Bag Chamber	
		Quantity - Length	Total Carbon Weight	Secondary Cartridge Filters w/ Bulk Carbon	
				Cartridges # - Length	Total Carbon Weight
3CT-6	0-90	1-6"	0.4lbs.	NA	NA
3CT-1	60-150	1-10"	0.6lbs.		
3CT-2	120-300	1-20"	1.2lbs.		
3CT-3	180-450	1-30"	1.8lbs.		
4CT-1	60-150	1-10"	0.6lbs.		
4CT-2	120-300	1-20"	1.2lbs.		
4CT-3	180-450	1-30"	1.8lbs.		
6CT-3	280-450	3-10"	1.8lbs.	3-6"	5lbs.
6CT-6	300-540	C/F	C/F		
6CT-9	450-720				
8CT-5	300-750	5-10"	3.0lbs.	NA	NA
8CT-10	500-900	C/F	C/F	5-6"	9lbs.
8CT-15	750-1200			5-10"	18lbs.
8CT-20				5-10"	25lbs.
12CT-12	720-1800	12-10"	7.2lbs.	NA	NA
12CT-24	1200-1920	C/F	C/F	12-6"	35lbs.
12CT-36	1800-2520			12-10"	50lbs.
12CT-48				12-10"	70lbs.

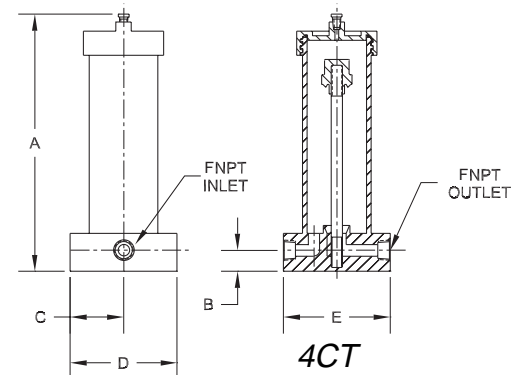
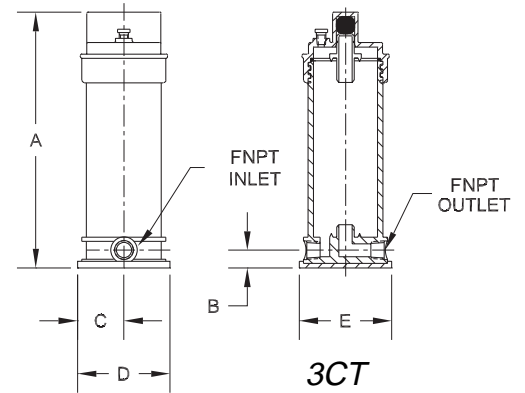

Series CT Dimensions

Chamber Model	Connections		Dimensions							Shipping Weight
	Inlet	Outlet	A	B	C	D	E	F	G	
3CT-6	3/4"	3/4"	10 1/2	1	2 5/8	5 1/4	5 1/4	N/A	N/A	3
3CT-1			14 1/2							4
3CT-2			24 1/2							6
3CT-3	1"	1"	34 1/2	1 3/8	3 1/2	7	7	N/A	N/A	8
4CT-1			17 1/8							7
4CT-2			27 1/8							10
4CT-3			37 1/8							13
6CT-3	1 1/2"	1 1/2"	22	3 3/8	5	10	N/A	22 3/4	28 1/2	27
6CT-6			32							36
6CT-9			42							45
8CT-5	1 1/2"	1 1/2"	23 1/8	2 3/8	6	12	N/A	25	31	33
8CT-10			33 1/8							45
8CT-15			43 1/8							57
8CT-20			53 1/8							69
12CT-12	1 1/2"	1 1/2"	22 3/4	2 1/4	8	16	N/A	24 3/4	30 3/4	70
12CT-24			32 3/4							90
12CT-36			42 3/4							110
12CT-48			52 3/4							130

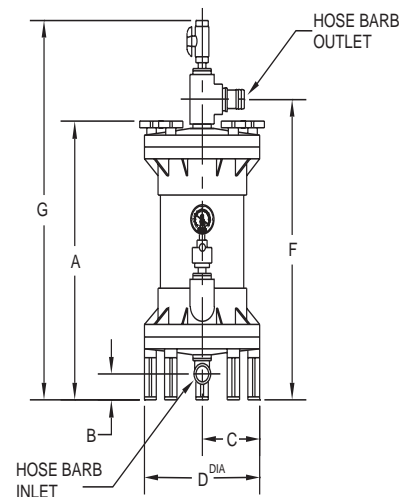

6CT/8CT/12CT

Series CB

Filter Bag Chambers

Penguin Chambers

Series CB Specifications

Chamber Style	GPH based on 70° Water	Filter Bag	
		Bag Diameter	Bag Length
6CB-6	up to 1500	5"	20"
6CB-9	up to 3000		30"
8CB-10	up to 2400	7"	16"
8CB-15	up to 4800		32"

Series CB Dimensions

Chamber Model	Connection		Dimensions						Shipping Weight
	Inlet	Outlet	A	B	C	D	E		
6CB-6	1"	1"	32	32 7/8	5	10	3 3/8	36	
6CB-9			42	42 7/8				45	
8CB-10	1 1/2"	1 1/2"	33 1/8	34 7/8	6	12	2 3/8	45	
8CB-15			43 1/8	44 7/8				57	

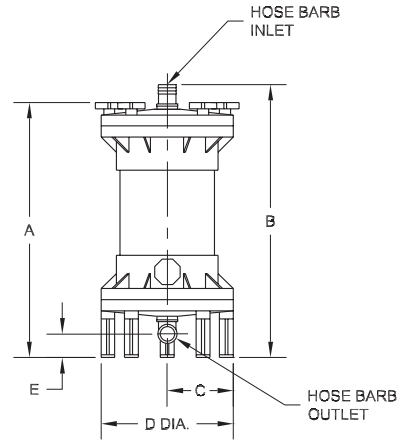

6CB/8CB

Series CN

In-Tank Filter Chambers

Series CN Specifications

Chamber Style	GPH based on 70° Water	No. & Length of Cartridge		
		Wound Cartridge	Pleated Cartridge	
	Wound Cartridge		DOE	SOE
3CN-1	150-300	1-10"	1-10"	NA
3CN-2	300-540	1-20"	1-20"	
3CN-3	450-770	1-30"	1-30"	
6CN-6	900-1620	3-20"	3-20"	2-20"
6CN-9	1350-2160	3-30"	3-30"	2-30"

Series CN Dimensions

Chamber Model	Connections		Dimensions										Shipping Weight
	Inlet	Outlet	A	B	C	D	E	F	G	H	J	K	
3CN-1			14 3/8							5		3 1/4	4
3CN-2	3/4"	3/4"	24 3/8	3/4	2 3/8	4 3/4	N/A	N/A	3/8	5 1/2	8	3	6
3CN-3			34 3/8										8
6CN-6	1"	1"	29 1/8	5	3 7/8	7 3/4	9/16	36 1/2	3/4	10	14	6	36
6CN-9			39 1/8					46 1/2					45

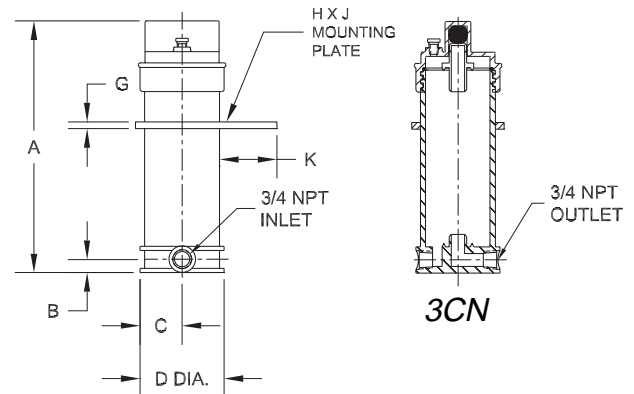

3CN

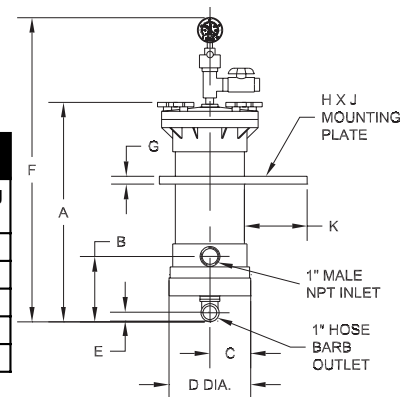

6CN

Series C

Dual Filter Cartridge Chambers

Penguin Chambers

Series C Specifications

Chamber Style	GPH based on 70° Water *Wound Cartridge	Cartridge No. & Length		
		Wound Cartridge	Pleated Cartridge	
			DOE	SOE
2-6C-6	1350-2430	6-20"	6-20"	4-20"
2-6C-9	2025-3240	6-30"	6-30"	4-30"
2-8C-10	2250-4050	10-20"	10-20"	8-20"
2-8C-15	3375-5400	10-30"	10-30"	8-30"
2-12C-24	5400-8640	24-20"	24-20"	18-20"
2-12C-36	8100-11340	24-30"	24-30"	18-30"

* Higher flows available with pleated cartridges.

Series C Dimensions

Chamber Model	Connections		Dimensions											Shipping Weight	
	Inlet	Outlet	A	B	C	D	E	F	G	H	J	K	L		M
2-6C-6	1 1/2"	2-1"	33 1/2	13 1/4	18	5 1/2	12 7/8	7 1/4	5 1/2	5	40 7/8	1 1/2	18	36	90
2-6C-9			43 1/2											50 7/8	
8-6C-10	2"	2-1 1/2"	34 5/8	13 1/2	20	5 1/2	13 3/4	7 7/8	6 1/2	5	42 1/2	1 1/2	20	40	130
8-6C-15			44 5/8												
2-12C-24	3"	2-1 1/2"	34 3/8	13 1/2	20	5 1/2	13 3/4	7 7/8	6 1/2	5	42 1/4	1 1/2	24	40	210
2-12C-36			44 3/8												

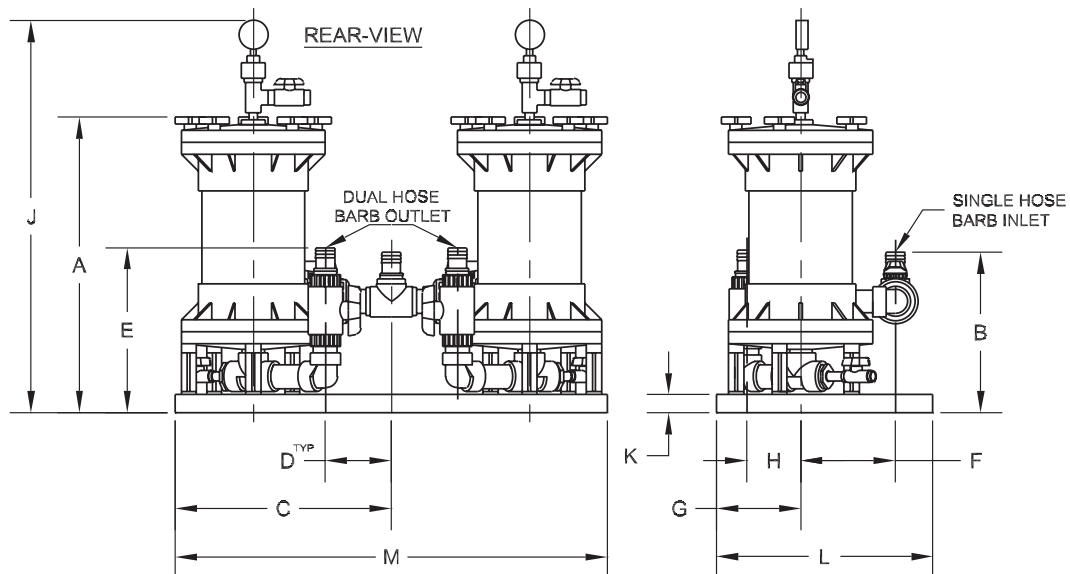

Series CT

Dual Carbon Treatment Chambers

Penguin Chambers

Series CT Specifications

Chamber Style	GPH based on 70° Water	Bulk Carbon Bag Chamber	
		Cartridge Filters w/ Bulk Carbon	
		Quantity - Length	Total Carbon Weight
2-6CT-6	450-810	6-6"	10lbs.
2-6CT-9	675-1080	6-10"	20lbs.
2-8CT-10	750-1350	10-6"	18lbs.
2-8CT-15	1125-1800	10-10"	36lbs.
2-12CT-24	1800-2800	24-6"	70lbs.
2-12CT-36	2700-3780	24-10"	100lbs.

Series CT Dimensions

Chamber Model	Connections		Dimensions													Shipping Weight
	Inlet	Outlet	A	B	C	D	E	F	G	H	J	K	L	M		
2-6CT-6	1 1/2"	2-1"	33 1/2	13 5/8	18	11 1/2	34 1/4	7 3/4	5 1/2	3 3/4	40	1 1/2	18	36	90	
2-6CT-9			43 1/2				44 1/4				50					110
8-6CT-10	2"	2-1 1/2"	34 5/8	15 1/4	20	11 1/2	36 1/2	8 3/4	6 1/2	4 1/2	42 1/2	1 1/2	20	40	130	
8-6CT-15			44 5/8				46 1/2				52 1/2					144
2-12CT-24	3"		34 3/8	15 1/8			36 1/4	10 3/4			42 1/4		24		210	
2-12CT-36			44 3/8				46 1/4				52 1/4					250

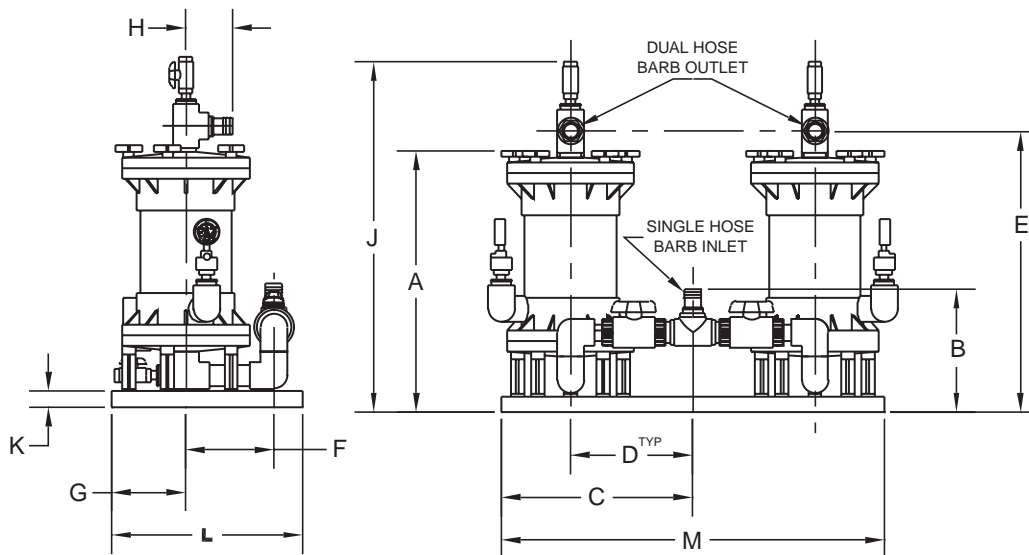

Series C/CT/CN/CB

Penguin Chambers

Engineering Specifications

Temperature Correction Factors: Temperature (°F) vs Pressure			
Operating Temp. °F	Correction Factors		
	CPVC	POLYPRO	PVDF
73	1.0	1.0	1.0
80	0.94	0.93	0.93
90	0.86	0.83	0.87
100	0.78	0.71	0.82
110	0.71	0.66	0.76
120	0.64	0.58	0.71
130	0.57	0.51	0.65
140	0.50	0.40	0.61
150	0.43	0.38	0.57
160	0.37	0.23	0.54
180	0.20	N/R	0.47
200	N/R	N/R	0.41
210	N/R	N/R	0.38
220	N/R	N/R	0.35
240	N/R	N/R	0.31
250	N/R	N/R	0.22
280	N/R	N/R	N/R
290	N/R	N/R	N/R

End Cap Configuration	
Single Open End (SOE)	
Double Open End (DOE)	Description
DOE	Flat Gasket
SOE	External Double 222 O-rings/ button end cap

Filter Chamber Recommended Operating Pressures (psi)			
Chamber Model	Maximum Operating Pressure Based on 73°F Water		
	CPVC	POLYPRO	PVDF
3C/3CT	80psi	40psi	80psi
4C/4CT	80psi	40psi	80psi
6C/6CT/6CB	70psi	40psi	
8C/8CT/8CB	70psi	40psi	60psi
12C/12CT	60psi	40psi	

Recommended Operating Pressure x T

emperature Correction Factor = Maximum Pressure

Nomenclature

No symbol = single chamber 2 = chambers manufactured together in parallel/ individually valved (single inlet/dual outlet)	Chamber Diameter	Chamber Series	No. of 10" length in Chamber	Construction Material/ O-ring Elastomer Material	End Cap Configuration
	3 = 3" 4 = 4" 6 = 6" 8 = 8" 12 = 12"	C = Filter CB = Filter bag CT = Carbon Treatment CN = In-Tank	1 = 1 2 = 2 3 = 3 5 = 5 6 = 6 10 = 10 12 = 12 15 = 15 24 = 24 36 = 36	A = CPVC/EPR B = Polypropylene/EPR C = PVDF/Viton	DOE = Blank SOE = Single open end
Not all combinations available. Consult factory.					
*3C-6 = 6"					

A Division of Penguin Pumps Inc.

7932 Ajay Drive, Sun Valley, CA 91352 • 818/504-2391 • 818/768-7590 FAX



Penguin Pumps

Sealless In-Tank Pumps Series P

Flows to 175 gpm

Corrosion-resistant CPVC, polypropylene or PVDF construction. No metal contact. No pump bearings, bushings or seals. Self priming when immersed. Runs dry without damage. Temperatures to 250°F.

Bulletin 201



Model P-7 1/2AK

CPVC 2-stage and 3-stage Horizontal Diffuser Pumps Series HD

Flows to 104 gpm

Pressure to 150 TDH in feet

A multi-stage pump in plastic. Designed for higher pressure applications, where a metal pump is not acceptable. CPVC construction and optional titanium shaft allows for temperatures to 180°F. Multi-stage pumps are available in 2-stage and 3-stage in 1 1/2hp, 2 hp, and 3hp. Series HD offers increased efficiency with smaller pump cases.

Bulletin 206



Model HD-2-3V

CPVC Horizontal Centrifugal Pumps Series HV & HN

Flows to 181 gpm

True volute design featuring the latest hydraulic technology -- energy efficiency, high flow and high pressure. CPVC construction where in contact with solution. No metal contact. All models available with double mechanical seal and water flush. Temperatures to 180°F. Optional priming chambers available for Series HV.

Bulletin 202/210



Model HV-3/4DV



Model HN-5D

Polypropylene Horizontal Centrifugal Pumps Series HOM

Flows to 132 gpm

These glass fiber reinforced polypropylene pumps with a simple energy-saving volute design offer easy maintenance and high operational efficiency. Ideal for many OEM and chemical processing applications. A completely metalless diplo seal provides reliability and easy installation. The V-clamp with knob allows for easy assembly and disassembly.

Bulletin 209



Model HOM-1/2E

Sealless Magnetic Drive Pumps Series M & MT

Flows to 250 gpm

Corrosion resistant, leakproof, sealless magnetic drive pumps with flows to 200 gpm. Series M constructed of polypropylene and/or ryton with optional 316SS, Kynar or Hastelloy construction. Series MT pumps are constructed of polypropylene or PVDF and can handle caustics to 220°F. Compatible with a wide range of acids and alkalis.

Bulletin 203/213



Model M-3/4B



Model MT-2C

316 Stainless Steel Centrifugal Pump Series HSC

Flows to 140 gpm

Corrosion resistant, stainless steel pumps ideal for many OEM and chemical processing applications. They feature high operational efficiency and easy maintenance, and are available with a single mechanical seal or double mechanical seal with water flush. Multi-stage model also available for high pressures to 140 TDH.

Bulletin 208



Model HSC-1/2SV