

# **LIGHTNIN<sup>®</sup>** *EV Series* *Portable Mixers*

**Economy and Value**  
from a name you  
know and trust.



**YOU AND LIGHTNIN. THE RIGHT MIX.**



**LIGHTNIN**

# LIGHTNIN EV Mixers.

## Superior economy and value for single-purpose mixing applications.

Now you can buy just as much mixer capability as you need for your specific application, without having to buy features and options that are more than you require. Plus, you get all the quality and reliability you'd expect from the world leader in fluid mixing technology.

- 280 and 350 RPM Gear Drive units feature lower speeds and higher torque for mixing large batches of low-viscosity fluids or smaller batches of high-viscosity fluids.
- Self-aligning, floating gears optimize load sharing and reduce wear.
- 1,725 RPM Direct Drive units are designed for small batch mixing plus high fluid shear applications.
- Switch, cord and plug are **standard** on all single-phase, 60 Hz, non-explosion proof units.
- Flexible motor coupling reduces mechanical starting loads for extended gear life.
- Permanently sealed lubrication reduces maintenance costs.
- Oversized bearings provide superior shaft support.
- Includes LIGHTNIN's 100% performance guarantee.



*Variable Speed control is available on all electric models, except XP models.*



*Optional 1/4 to 3/4 hp cool-running air motors can be used in flammable or explosive environments, and in ambient temperatures up to 250°F (120°C).*



*Optional flange mount (above) or plate mount (left) bases are available.*

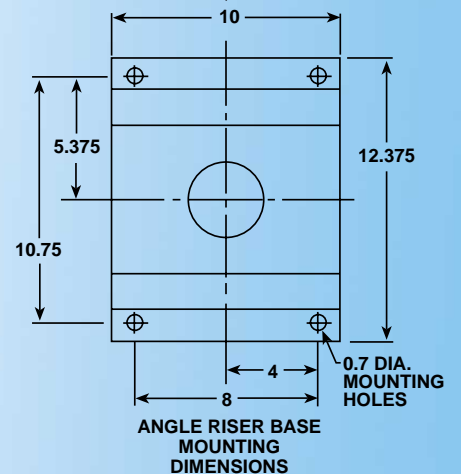
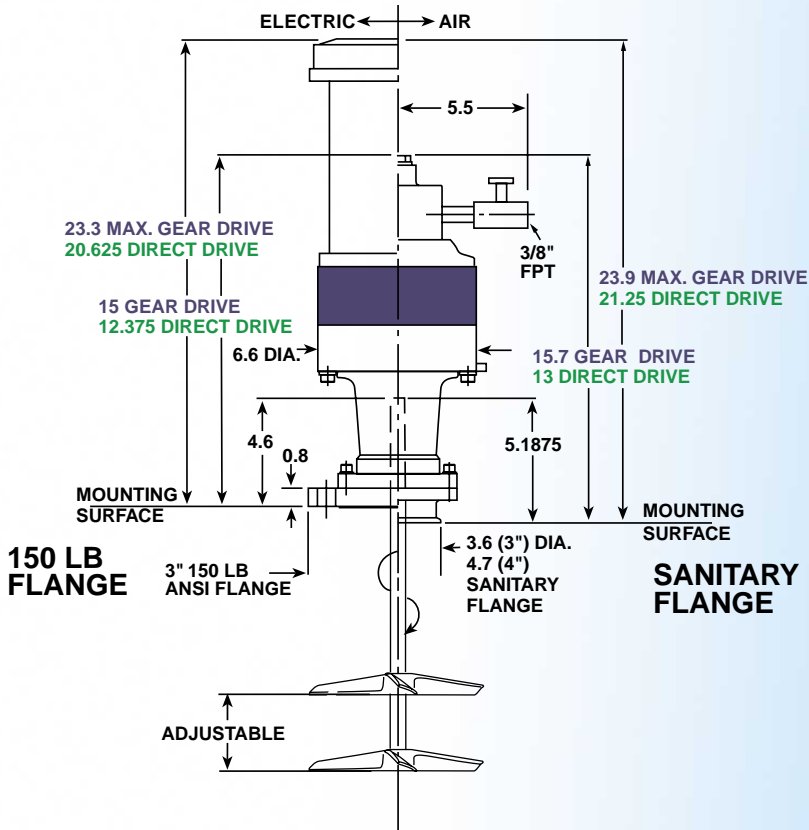
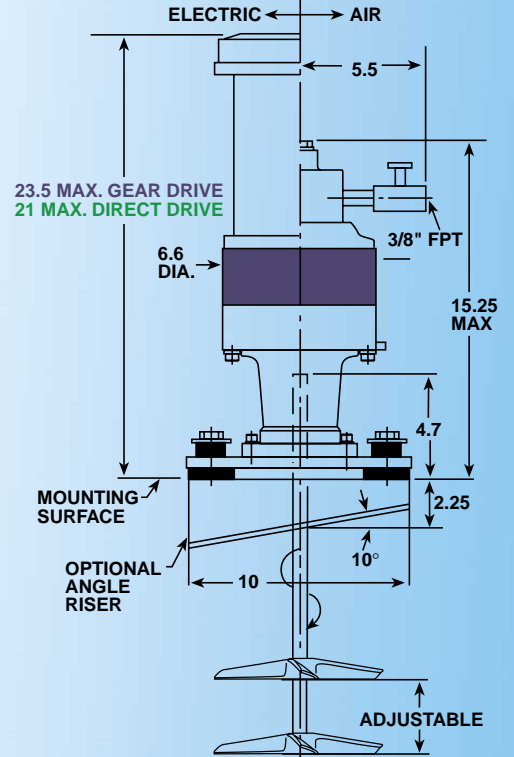
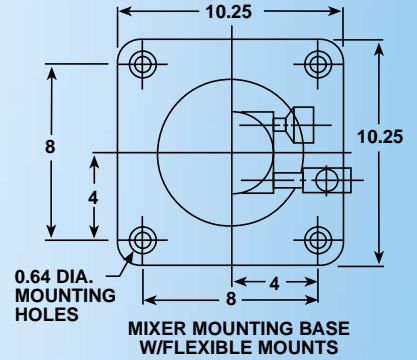
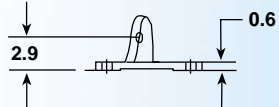
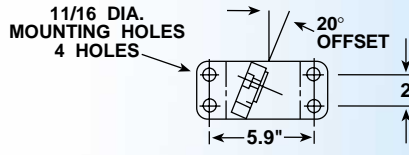
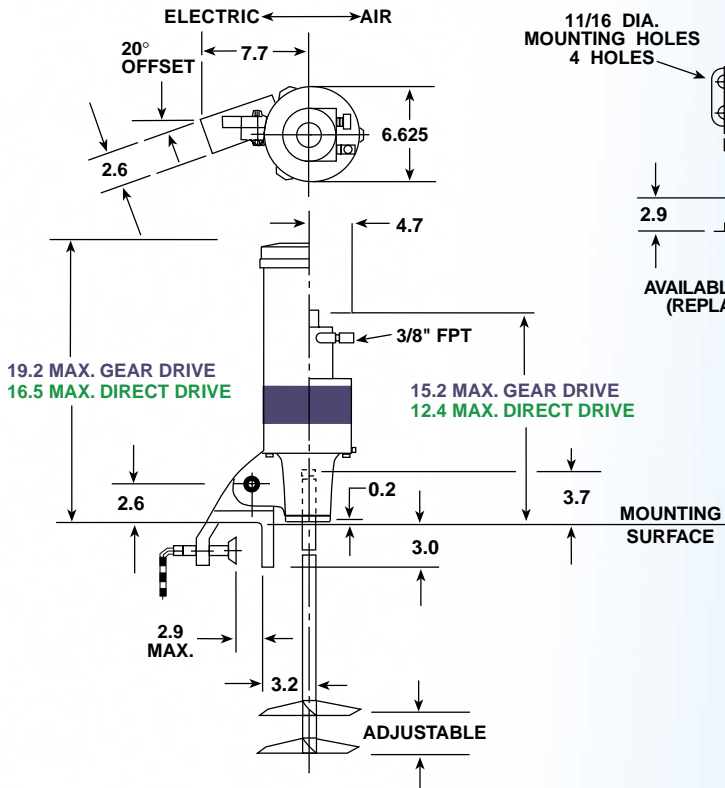

Learn more about these and other high-performance mixers from **LIGHTNIN**. Call 1-888-MIX BEST for product literature or visit our web site at [www.Lightnin-Mixers.com](http://www.Lightnin-Mixers.com)

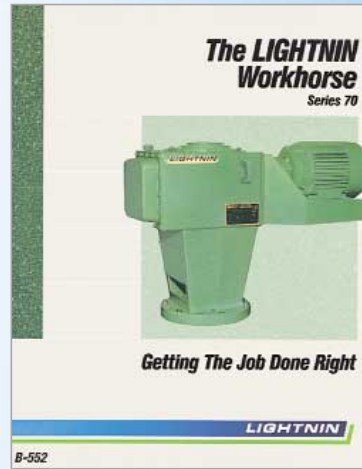

B-552

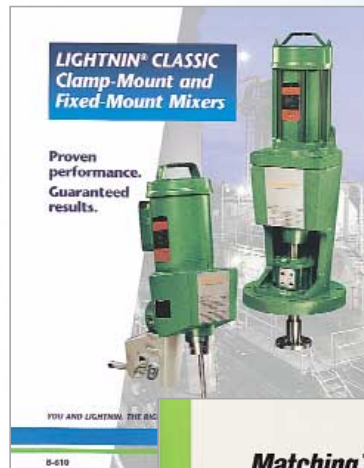

B-610

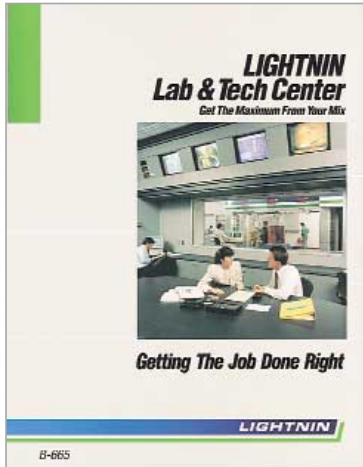

B-665

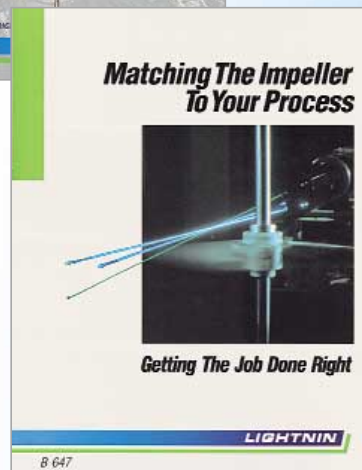

B-647

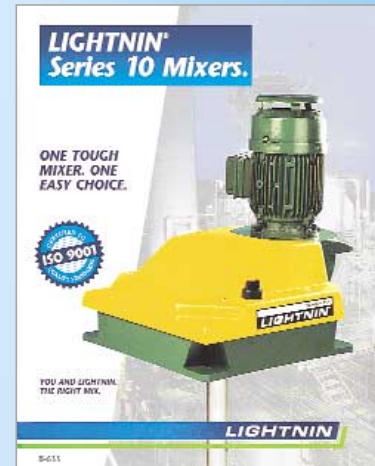

B-633

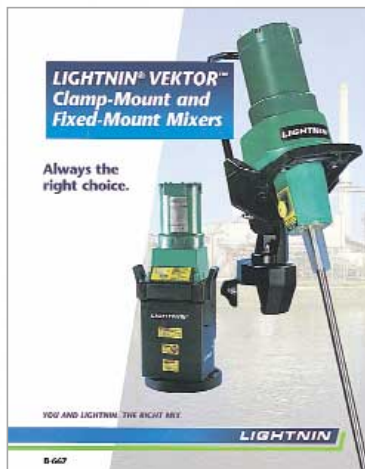

B-667

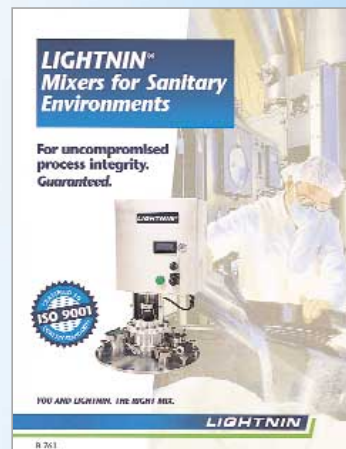

B-761

**LIGHTNIN**

135 Mt. Read Blvd., P.O. Box 1370, Rochester, New York 14603  
 Telephone: 716-436-5550 Fax: 716-436-5589  
[www.LIGHTNIN-MIXERS.COM](http://www.LIGHTNIN-MIXERS.COM)

Rochester, NY, USA • Toronto, Canada • Poynton, England  
 Jurong, Singapore • Sydney, Australia • Milan, Italy  
 Johannesburg, South Africa • Shanghai, China